

Batley Valve

Installation, Operation & Maintenance Manual

BV10000 Standard Swing Through Valve 50-2000mm



IOM-B1-R0

Contents	Page
Introduction	1
Scope of the Manual	1
Description	1
Specification	1
Installation	1
Operation	2
Maintenance	2
Packing Replacement	2
Vane & Shaft Replacement	2
General Maintenance	3
Optional Parts	3
Parts Ordering	4

INTRODUCTION

Scope of This Manual

This manual is intended to provide installation, maintenance and parts information for our "Standard" Butterfly Valve in sizes 50-2000mm.

Reference should be made to separate instruction manuals for information covering the actuator and accessories.

Only personnel qualified through training or experience should install, maintain and operate this Butterfly valve.

If there are any questions concerning these instructions contact your local Sales Office.

Description

The Standard butterfly valve is of a heavy duty design with a swing through vane and is used on general control applications where very low leakage rates are not required.

Specification

Valve bodies are designed to meet the pressures as designated in ANSI B16.34 and comply with ANSI, BS, DIN and JIS flange standards.

Valves supplied to suit one flange standard are not generally interchangeable with other standards.

All sizes are compatible with weld neck and slip on flanges of schedule 80 or less. Contact the sales office to check compatibility with higher pipe schedules.

All valves can be installed with the flow in either direction.

All valve sizes have approximately equal percentage characteristics when fitted with a standard trim.

INSTALLATION

1. Prior to installation care should be taken to ensure that both the pipe flanges and the valve faces are free from foreign material.
2. Ensure that the mating flanges are parallel and in line with each other.
3. Check that the valve is in the fully closed position.
4. Ensure that the flanges are spread far enough apart to allow insertion of the valve and its gaskets.
5. Whilst supporting the valve, install two flange bolts through both flanges to centralise and support the valve prior to installation of the remaining line bolts and flange gaskets.
6. Hand tighten the flange bolts using a diametrically opposed sequence.
7. Open the valve slowly to ensure that the vane clears the mating pipework.
8. Fully tighten the flange bolts evenly and re-check for correct operation.

WARNING

The butterfly valve is not necessarily earthed when installed in the pipeline. If the valve is on a flammable or hazardous duty an explosion could result from a static discharge from the valve components.

To avoid this situation make sure the valve body is earthed to the pipeline prior to putting the valve into operation.

OPERATION

Ensure that all the operator connections have been made in accordance with the manufacturers instructions and that the recommended pressures and voltages of all electrical equipment have been correctly adjusted.

Check all gland nuts and ensure that they are tight but **do not over tighten** the packing gland. This however, may require adjustment after a period of operation due to the packing settling down.

For valves which have both operators and shaft mounted declutchable handwheels, under no circumstances engage the handwheel with the valve on automatic control. Make absolutely certain that the handwheel is disengaged before allowing air to the operator.

MAINTENANCE

Packing Replacement

This procedure can be performed without removing the actuator if split packing rings have been used. When other types of none split packing rings have been used, the actuator must be removed from the valve.

1. Isolate the valve and release all pressure from the valve body. If the actuator has to be removed disconnect the power supply. Make sure that on spring return actuators the spring is in the relaxed position.
2. Unscrew the gland follower nuts (10) and slide the gland follower (8) off the valve shaft.
3. Remove the old packing rings (7) taking care not to scratch the shaft or packing box bore as this may prevent the new packings from sealing correctly.
4. Remove the gland ring (6)
5. Clean the inside of the packing box and steel components thoroughly before re-assembly.
6. Install the gland ring (6) and packing rings (7) making sure that the joints on the split rings do not line up to form a possible leak path.

CAUTION

Except on oxygen duty lightly lubricate new PTFE and GRAPHITE Packings with a silicon base lubricant.

7. Replace the gland follower (8), spring washers (11) and gland nuts (10). Finger tightening of the gland nuts (10) should provide ample pressure to the packing rings. When the valve is placed in service this adjustment should be checked and the nuts tightened just enough to prevent any leakage. Too much tightening will bind the shaft and prevent a sensitive valve response. Ensure that the gland follower (8) is not cocked over as this could bind on the shaft.
8. Extra care should be taken when handling fragile graphite packings to avoid damage both prior and during installation.

Batley Valve

Installation, Operation & Maintenance Manual

BV10000 Standard Swing Through Valve 50-2000mm



IOM-B1-R0

Replacing the Vane and Shaft

This procedure is to be performed when replacement of the valve vane, shaft, taper pins or bearings are required.

1. Remove the actuator mounting nuts and bolts and then dismantle the actuator from the valve. Make sure that on spring return actuators the spring is in the relaxed position.
2. Rotate the vane (2) to the fully closed position.
3. Locate the split taper pins (4) and drive out the pins towards the larger end. Where parallel pins are fitted, loosen and remove the setscrews then remove all covers and gaskets. Extract the pins using the tapped end in the end of the pin.
4. Unscrew and remove the gland follower nuts (10) and slide off the gland follower (8).
5. Unscrew the blank end plate screws (14) and remove the blank end plate (12) from the non-drive end of the valve.
6. Remove and discard gasket (13)
7. Pull the shaft(s) (3) out through the actuator side of the valve. On valves of 250mm and larger the shaft is in 2 pieces, the non-drive end shaft can be pulled out using a tapped hole in the shaft end.
8. With the shafts extracted the vane (2) can be removed.
9. Remove the gland packings (7) and gland ring (6) from the valve body.
10. If either of the bearings (5) require replacement, carefully remove them from the valve. Bearings could be glacier D.U., Ni-Resist or Metoplast MP3 or MP2 dependant on service conditions.
11. Carefully check and clean all parts that are to be re-used.
12. Replace the bearings (5) and then locate the vane into position within the valve body and insert the shaft(s) (3) into position.

13. Align the shaft with the existing pin holes and loosely insert the taper/parallel pins (4). Check the vane rotation for smooth operation.
14. Drive in all taper pins (4) until a solid contact is felt and then open out the split end of the pins to prevent loosening during service. If parallel pins are fitted, drive in the pins until solid contact is felt and replace gaskets and cover plates and tighten setscrews. Ensure the tapped end of the pin is visible when the pin is inserted to enable future removal.
15. Locate gasket (13) on the non-drive end flange.
16. Replace the blank end plate (12) and lock in position with spring washer (15) and blank end plate screws (14).
17. Re-check for smooth operation and then insert the gland packings in accordance with the section on packing replacement.
18. On completion of this the actuator can be refitted and the valve action checked.

Note - If a new vane is required a complete vane and shaft assembly must be purchased to avoid damage to existing valve parts.

General Maintenance

Valve body parts will be subject to normal wear and must be inspected and replaced as necessary. The frequency of this inspection and routine maintenance depends on the severity of the service conditions.

Optional Parts

The Standard butterfly valve can be fitted with a variety of optional extras, the most common of which are listed below, where required additional maintenance sheets can be provided giving extra instructions required for the maintenance of these parts.

1. Out board Bearings.
2. Lubricated packing boxes
3. Varidiff anticavitation trim.
4. Spring loaded packing box.
5. Bearing purge connection.
6. Open and close bonnets for use on high temperature and cryogenic duties.

WARNING

To avoid personal injury isolate the valve from all pressure and relieve trapped pressure from the valve body before attempting any maintenance work.

PARTS ORDERING

When corresponding with our Sales department, with regard to the supply of spare parts, always mention the valve serial number. Only genuine Batley spare parts should be used.

Fig 1. One Piece Shaft Design 50mm to 200mm Through Shaft Design

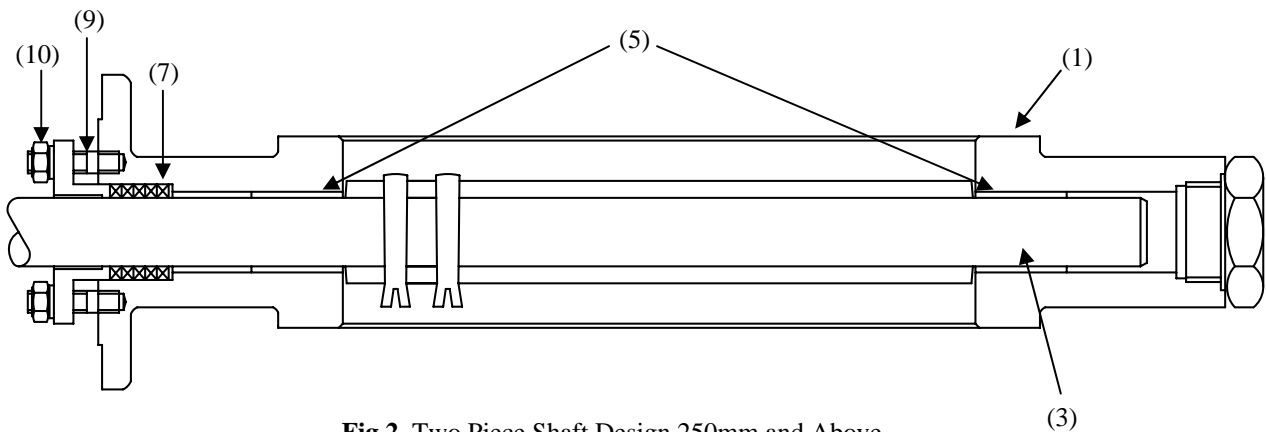

Fig 2. Two Piece Shaft Design 250mm and Above

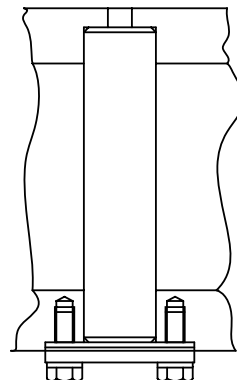
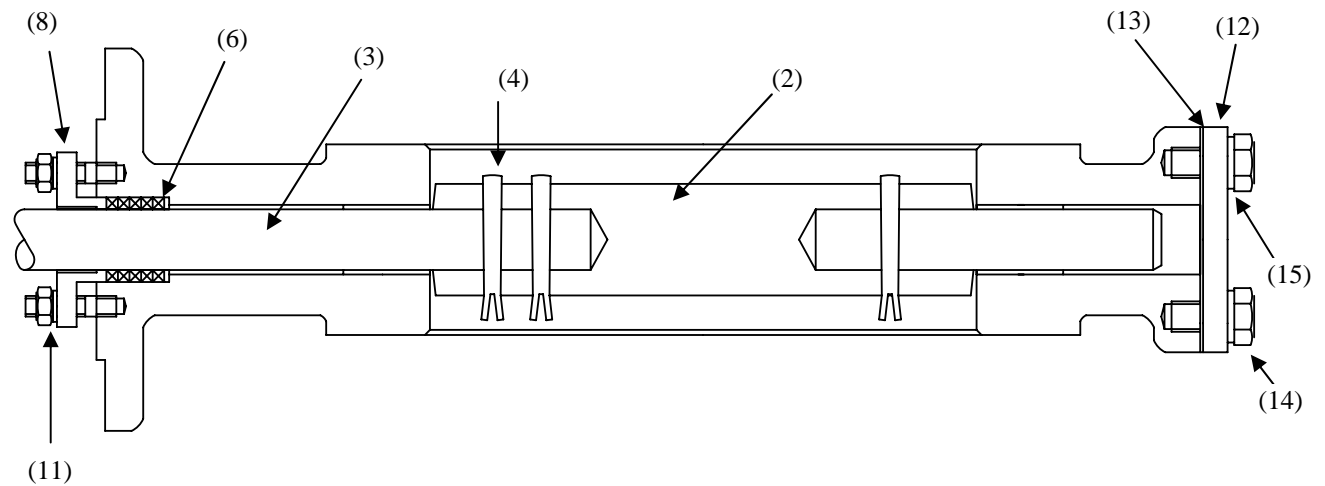

Fig 3. Detail of Parallel Pin

Item	Description	Item	Description
1	Valve Body	9	Follower Studs
2	Vane	10	Follower Nuts
3	Shaft	11	Spring Washer
4*	Split Taper Pin	12	Blank End Plate
5*	Bearings	13*	Gasket
6	Gland Ring	14	End Plate Screw
7*	Packing Rings	15	Spring Washer
8	Gland Follower		

* Recommended Spares for Valve