

## Batley Valve

Installation, Operation & Maintenance Manual

### BV26000 Metalseal 50-1600mm With Clamp Rings



IOM-B10-R0

Contents	Page
<b>Introduction</b>	<b>1</b>
Scope of the Manual	1
Description	1
Specification	1
<b>Installation</b>	<b>1</b>
<b>Operation</b>	<b>2</b>
<b>Maintenance</b>	<b>2</b>
Packing Replacement	2
Replacing the Vane & Shaft	3
Seal Ring Replacement	3
General Maintenance	4
Optional Parts	4
<b>Parts Ordering</b>	<b>4</b>
<b>Sectional Drawings</b>	<b>5</b>

## INTRODUCTION

### Scope of This Manual

This manual is intended to provide installation, maintenance and parts information for our "Metalseal" Butterfly Valve in sizes 50-1600mm.

Reference should be made to separate instruction manuals for information covering the actuator and accessories.

Only personnel qualified through training or experience should install, maintain and operate this control valve.

If there are any questions concerning these instructions contact your local Sales Office.

### Description

The Metalseal type control valve has an eccentrically mounted vane secured to the shaft with taper pins. The valve has a keyed shaft for use with power and manual actuators, for ON/OFF and throttling applications.

## Specification

Valve bodies are designed to meet the pressures as designated in ANSI B16.34 and comply with ANSI, BS, DIN and JIS flange standards.

Valves supplied to suit one flange standard are not interchangeable with other standards.

All sizes are compatible with weld neck and slip on flanges of schedule 80 or less.

Valves can only be installed with flow in one direction as indicated by the flow arrow marked on the body. Reverse flow is permissible, but the sales office should first be contacted for confirmation.

All valve sizes have approximately equal percentage characteristics when fitted with a standard trim.

## INSTALLATION

1. Prior to installation care should be taken to ensure that both the pipe flanges and the valve faces are free from foreign material.
2. Ensure that the mating flanges are parallel and in line with each other.
3. Check that the valve is in the fully closed position.

### CAUTION

**Rotating the vane past either the open or closed position could result in damage to the seal, vane or sealing surfaces. With the exception of the slave valve on three way assemblies all valves are supplied clockwise to close.**

4. Ensure that the flanges are spread far enough apart to allow insertion of the valve and its gaskets.
5. Whilst supporting the valve, install two flange bolts through both flanges. With lugged valves it is recommended four stud bolts are used to support the valve i.e. two at each side of the valve. The valve may be rested against these two bolts while the flange gaskets, and the remainder of the flange bolts, are fitted.

### Batley Valve

Installation, Operation & Maintenance Manual

### BV26000 Metalseal 50-1600mm With Clamp Rings



IOM-B10-R0

6. Hand tighten the flange bolts using a diametrically opposed sequence.
7. Open the valve slowly to ensure that the vane clears the mating pipework.
8. Fully tighten the flange bolts evenly and re-check for correct operation.

#### WARNING

The butterfly valve is not necessarily earthed when installed in the pipeline. If the valve is on a flammable or hazardous duty an explosion could result from a static discharge from the valve components.

To avoid this situation make sure the valve body is earthed to the pipeline prior to putting the valve into operation.

#### OPERATION

Ensure that all the operator connections have been made in accordance with the manufacturers instructions and that the recommended pressures and voltages of all electrical equipment have been correctly adjusted.

Check all gland nuts and ensure that they are tight but **do not over tighten** the packing gland. This however, may require adjustment after a period of operation due to the packing settling down.

For valves which have both operators and shaft mounted declutchable handwheels, under no circumstances engage the handwheel with the valve on automatic control. Make absolutely certain that the handwheel is disengaged before allowing air to the operator.

#### MAINTENANCE

##### *Packing Replacement*

This procedure can be performed without removing the actuator if split packing rings have been used. When other types of none split packing rings have been used, the actuator must be removed from the valve.

1. Isolate the valve and release all pressure from the valve body. If the actuator has to be removed disconnect the power supply. Make sure that on spring return actuators the spring is in the relaxed position.
2. Unscrew the gland follower nuts (10) and spring washers (11). Slide the gland follower (8) off the valve shaft.
3. Remove the old packing rings (7) taking care not to scratch the shaft or packing box bore as this may prevent the new packings from sealing correctly.
4. Remove the gland ring (6)
5. Clean the inside of the packing box and steel components thoroughly before re-assembly.
6. Install the gland ring (6) and packing rings (7) making sure that the joints on the split rings do not line up to form a possible leak path.

#### CAUTION

Except on oxygen duty lightly lubricate new PTFE and GRAPHITE Packings with a silicon base lubricant.

7. Replace the gland follower (8), spring washers (11) and gland nuts (10). Finger tightening of the gland nuts (10) should provide ample pressure to the packing rings. When the valve is placed in service this adjustment should be checked and the nuts tightened just enough to prevent any leakage. Too much tightening will bind the shaft and prevent a sensitive valve response. Ensure that the gland follower (8) is not cocked over as this could also bind on the shaft.
8. Extra care should be taken when handling fragile graphite packings to avoid damage both prior and during installation.

### Batley Valve

#### Installation, Operation & Maintenance Manual

#### BV26000 Metalseal 50-1600mm With Clamp Rings



IOM-B10-R0

#### **Replacing the Vane and Shaft**

This procedure is to be performed when replacement of the valve vane, shaft, taper pins or bearings are required.

1. Remove the seal ring in accordance with instructions below.
2. Remove the actuator mounting nuts and bolts and then dismantle the actuator from the valve. Make sure that on spring return actuators the spring is in the relaxed position.
3. Rotate the vane (2) to the fully open position.
4. Locate the split taper pins (4) and drive out the pins towards the larger end. Where parallel pins are fitted, loosen and remove the setscrews then remove all covers and gaskets. Extract the pins using the tapped end in the end of the pin.
5. Unscrew and remove the gland follower nuts (10) and slide off the gland follower (8).
6. Unscrew the blank end plate screws (14) and remove the spring washers (15) and blank end plate (12) from the non-drive end of the valve.
7. Remove and discard gasket (13)
8. Pull the shaft (3) out through the actuator side of the valve. If the shaft cannot be pulled free, carefully use a punch to drive the shaft out from the side opposite the actuator.
9. Remove the vane (2) and vane spacers (16) from the valve body. On valves with metal bearings vane spacers are not used.
10. Remove the gland packing (7) and gland ring (6) from the valve body.
11. If either of the bearings (5) require replacement carefully remove them from the valve.
12. Carefully check and clean all parts that are to be re-used.
13. Replace the bearings (5) by inserting them from within the bore of the valve, ensuring that the flange is fully in its recess.
14. Insert the vane spacers (16) into position in the bore of the valve. On valves with metal bearings vane spacers are not used.
15. Locate the vane into position within the valve body and insert the shaft (3) into position.
16. Slide the shaft through the body and vane. Align the shaft with the existing pin holes and loosely insert the taper pins (4). Check the vane rotation for smooth operation.
17. Drive in all taper pins (4) until a solid contact is felt and then open out the split end of the pins to prevent loosening during service. If parallel pins are fitted, drive in the pins until solid contact is felt and replace gaskets and cover plates and tighten setscrews. Ensure the tapped end of the pin is visible when the pin is inserted to enable future removal.
18. Locate gasket (13) on the non-drive end flange.
19. Replace the blank end plate (12) and lock in position with spring washer (15) and blank end plate screws (14).
20. Re-check for smooth operation and then insert the gland packings and seal ring in accordance with the appropriate instructions in this bulletin.
21. On completion of this the actuator can be refitted. Care should be taken when re-fitting the actuator to ensure that the vane is not over travelled which will damage the seal. The actuator travel stops should be adjusted to prevent this from occurring. Consult the relevant actuator instructions for details of adjusting the stops.

#### **Seal Ring Replacement**

When it is found necessary to replace the seal ring the following procedures should be adopted.

1. Isolate the valve from the line pressure and relieve pressure from the valve body. Shut off and disconnect all lines from power operated actuators.
2. Whilst supporting the valve unscrew the flange bolts and remove the valve from the pipeline.

## Batley Valve

### Installation, Operation & Maintenance Manual

### BV26000 Metalseal 50-1600mm With Clamp Rings

- Care should be taken to ensure that the valve is in the fully closed position as damage to the vane may occur if removal is attempted when the vane is in the open position.
- Unscrew the cap screws (17) and remove the clamp ring (18) from the valve body.
- With the clamp ring removed the seal (19) and gasket (20) can now be taken out of the valve body and replaced.
- Prior to installation of the seal ring the vane should be in the closed position to allow accurate centring of the new seal.
- Clean all parts to remove all traces of the previous seals.
- Locate the replacement seal (19) and gasket (20) into the valve body.
- Lower the clamp ring (18) into position and lock in position with capscrews (17). Apply a downward force to the clamp ring to enable the shear ring to be pushed into place.
- The valve can now be leak tested.

#### General Maintenance

Valve body parts will be subject to normal wear and must be inspected and replaced as necessary. The frequency of this inspection and routine maintenance depends on the severity of the service conditions.

#### Optional Parts

The Metalseal butterfly valve can be fitted with a variety of optional extras, the most common of which are listed below, where required additional maintenance sheets can be provided giving extra instructions required for the maintenance of these parts.

- Out board Bearings.
- Lubricated packing boxes.
- Spring loaded packing box.
- Bearing purge connection.
- Open and close bonnets for use on high temperature and cryogenic duties.

### WARNING

To avoid personal injury isolate the valve from all pressure and relieve trapped pressure from the valve body before attempting any maintenance work.

#### PARTS ORDERING

When corresponding with our Sales department, with regard to the supply of spare parts, always mention the valve serial number. Only genuine Batley spare parts should be used.

Item	Description	Item	Description
1	Valve Body	11	Spring Washer
2	Vane	12	Blank End Plate
3	Shaft	13*	Gasket
4*	Split Taper Pin	14	End Plate Screw
5*	Bearings	15	Spring Washer
6	Gland Ring	16	Vane Spacer
7*	Packing Rings	17	Capscrew
8	Gland Follower	18	Clamp Ring
9	Follower Studs	19*	Seal
10	Follower Nuts	20*	Gasket
* Recommended Spares for Valve			

**Fig 1. One Piece Shaft Design With Plugged End**

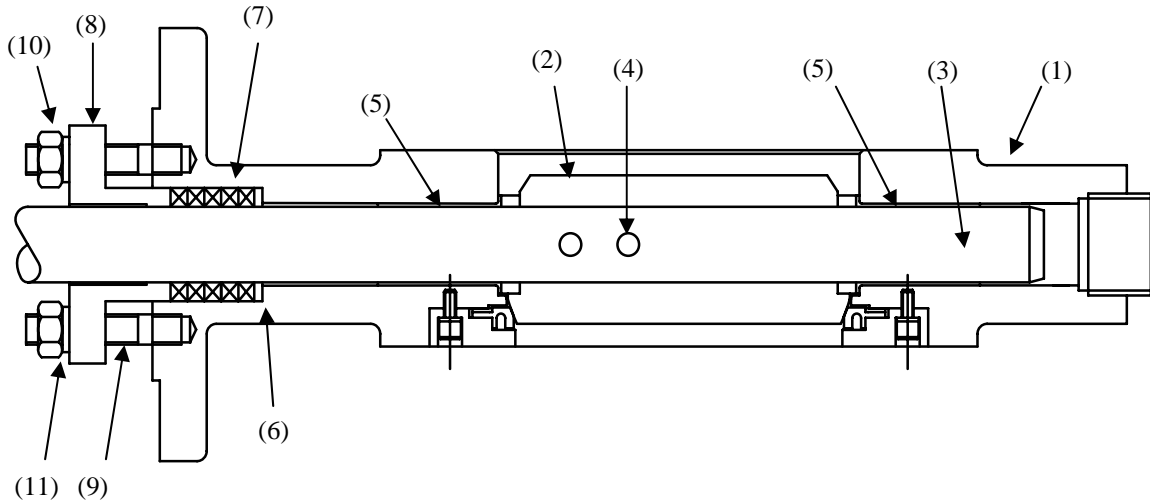

**Fig 2. One Piece Shaft Design With Blank End Plate**

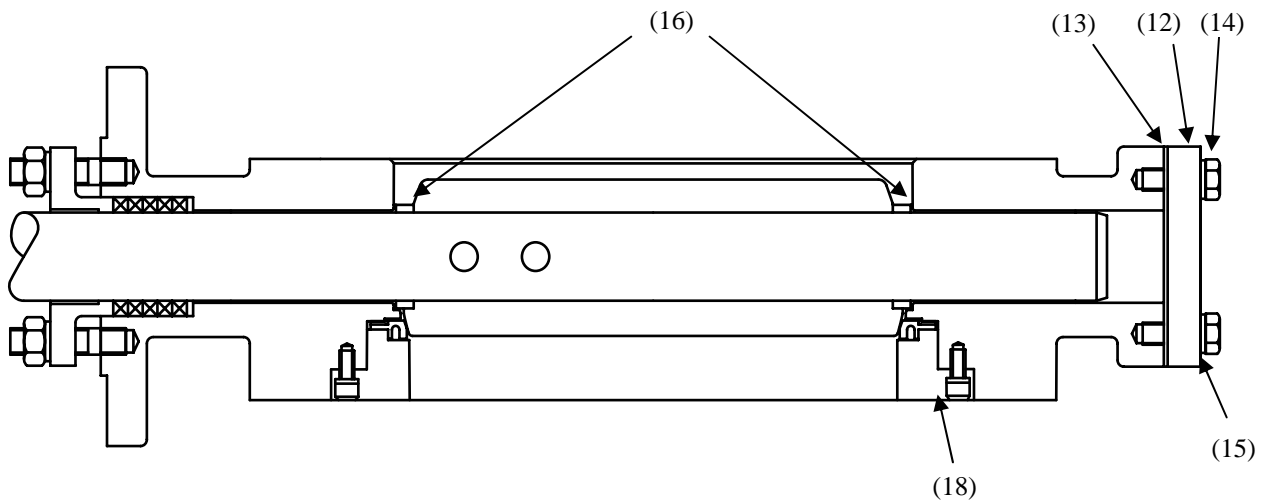

**Fig 3. Detail of Parallel Pin**

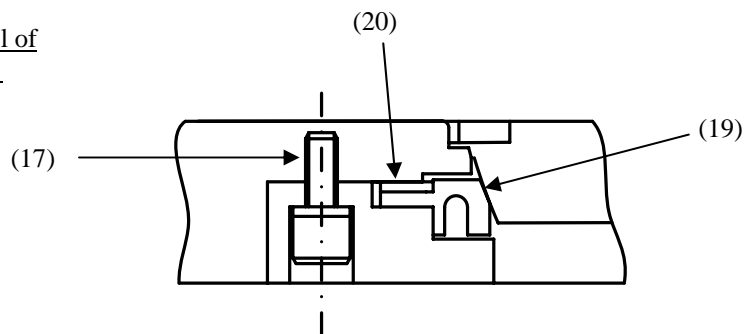
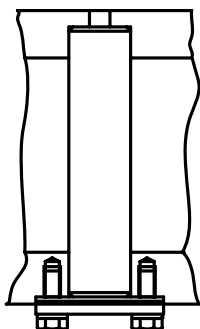

**Fig 4. Detail of Seal Assembly**