

### SAFETY

**Safety** - consult Blakeborough publication 'Safety' before starting any maintenance work.

The valve and actuator should be handled and installed with care. Consult publication 'Good Installation Practices' for details.

Before any maintenance work it is essential to ensure that the valve and actuator assembly is isolated and depressurised.

### DESCRIPTION

Desuperheating is a convenient and efficient method of obtaining steam for process work from a superheated supply.

Superheated steam is passed through a section of pipe into which is fitted one or more spray nozzles depending upon capacity. These inject a fine spray of feed water into the steam, absorbing the heat from the steam and reducing the quantity of superheat. As the water is absorbed the steam supply is augmented.

The fixed orifice spray nozzle represents an economical method of installing a desuperheating system when it is desirable to obtain feed water from a separate control valve, for example, if the customer already has a suitable valve available.

The outlet steam temperature is controlled by regulating the flow of cooling water. A temperature controller senses variations in the steam temperature and relays a proportional signal directly to the actuator of the water control valve which governs the quantity of water passing the spray nozzle.

### INSTALLATION

The correct installation of the desuperheater is of prime importance with respect to ensuring good temperature control. The following guidelines are provided to ensure this is achieved.

The desuperheater should be installed in a straight length of pipe, ideally with a distance of 6 pipe diameters upstream. The minimum downstream length of straight pipe should be 4 metres. Where minimum distances cannot be met, long radius elbows should be used to minimise the potential for erosion caused by the impact of

water particles moving at high velocity impinging on the pipe wall.

To ensure that the piping drains correctly, it should be arranged to fall in the direction of flow by 20mm per metre. An adequately sized condensate trap should be provided at the lowest point in the pipework.

In order to achieve successful desuperheating it is important that pipework is maintained at the proper temperature. To avoid heat loss and erroneous temperature measurements the steam pipework should be lagged.

The spraywater should be clean and free of contamination. It should be effectively filtered to less than 0.25mm.

The distance from the desuperheater to the temperature sensing element is very important and varies between 7.5 and 30 metres depending upon pipe size, enthalpy change and proximity of the conditioned temperature to saturation. Details for calculating the required distance are given in publication BC-2.

The temperature measuring element should be located in a straight length of pipe, at least 2 metres from the nearest bend. The temperature pocket should extend into the pipe by approximately 1/2 the diameter on pipe sizes up to 300mm, and by a 1/3 on sizes above 300mm.

The desuperheater is designed to give the maximum atomisation of the water but it cannot be assumed that full evaporation takes place within the desuperheater pipe. In general, where the pipework layout incorporates bends, etc., between the injection nozzle and the temperature sensing point, the distance is usually less, due to the increased turbulence created at the bends etc., than it would be if the pipework were straight. Unfortunately every plant is different and it is difficult to say exactly where temperature stabilisation will occur.

**VALVE DISASSEMBLY**

1. Break the spot welds holding the retaining nut (46) to the nozzle body (1).
2. Unscrew the retaining nut (46). When the nut is allowed to drop onto the shoulder of the spray unit assembly (5) it will free the split retaining ring (45).
3. Withdraw the spray unit assembly (5) out of the nozzle body (1).
4. Remove the 'C' ring (44) from the top of the spray unit.
5. Break the spot welds holding the end cap (47) to the spray unit assembly (5).
6. Unscrew the end cap (47).
7. Unscrew the retaining ring (33).
8. Remove circlip (32).
9. Slide retainer (34) off the spray unit body (5).
10. Unscrew the spray insert (30) and swirl insert (31).

**VALVE ASSEMBLY**

1. Screw the swirl insert (31) and spray insert (30) into the spray unit body (5).
2. Clean the spray unit body (5) and replace the retainer (34) over the swirls, locating on the pin orientation (35).
3. Replace the circlip (32) on the spray unit body (5).
4. Tighten the retaining ring (33) to lock the retainer (34) in place.
5. Clean the desuperheater components thoroughly.
6. Clean the inside of the nozzle body (1), particularly the spray unit location bore and the 'C' ring sealing surface.
7. Make sure the 'C' ring groove, in the spray unit assembly, is perfectly clean, replace 'C' ring (44).
8. With the split retaining ring (45) in position, screw the retaining nut (46) back onto the nozzle body (1).
9. Spot weld the retaining nut (46) to the nozzle body (1).
10. Screw in the end cap (47) tightly and spot weld.

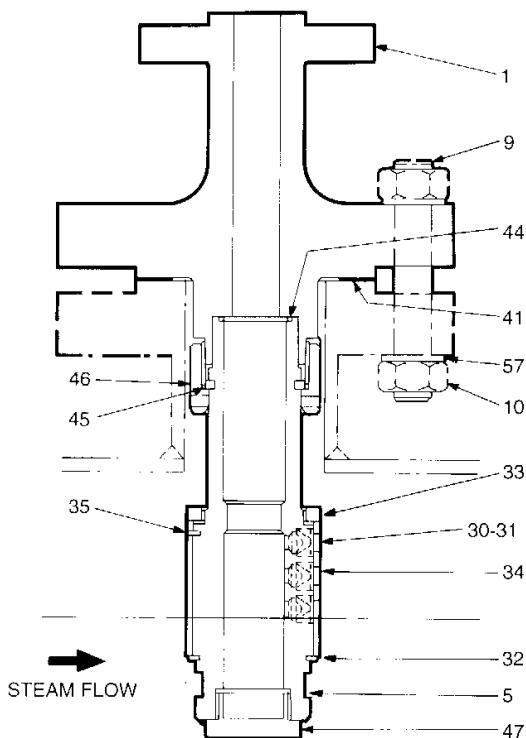

| PARTS LIST |                          |
|------------|--------------------------|
| 1          | BODY                     |
| 5          | SPRAY UNIT               |
| 9          | BRANCH FLANGE STUD       |
| 10         | BRANCH FLANGE NUT        |
| 30         | SPRAY INSERT*            |
| 31         | SWIRL INSERT*            |
| 32         | RETAINING SLEEVE CIRCLIP |
| 33         | RETAINING RING           |
| 34         | RETAINING SLEEVE         |
| 35         | RETAINING SLEEVE PIN     |
| 41         | BODY GASKET*             |
| 44         | 'C' RING                 |
| 45         | SPLIT RETAINING RING     |
| 46         | RETAINING NUT            |
| 47         | END CAP                  |
| 57         | WASHER                   |