

ROTO-JET PUMP

High Pressure Pitot Tube Pumps

Model 2200
Oil Lubricated

Excellent
Power & Industrial
Solutions



High pressure multi-stage performance with the cost advantage, simplicity, and reliability of a single-stage pump.

Benefits of the Roto-Jet 2200 Pump

- **Improved Design**

- Lower Energy Cost—Higher efficiencies using improved patented hydraulics
- Flexible Installation—Footprint interchangeable with Roto-Jet models RG and 2100
- Low Maintenance Cost—Simplified design means less maintenance

- **Enhanced Reliability**

- Fewer parts—Pick Up Tube Locknut design
- Seal designed for low pressure—improves overall seal life
- Isolated bearing pedestal— minimizes risk of bearing contamination

- **Improved Performance**

- Broad range of speed, flow, and pressure capability
- Hydraulically stable along the entire performance curve and beyond BEP
- Enhanced hydraulics over previous designs



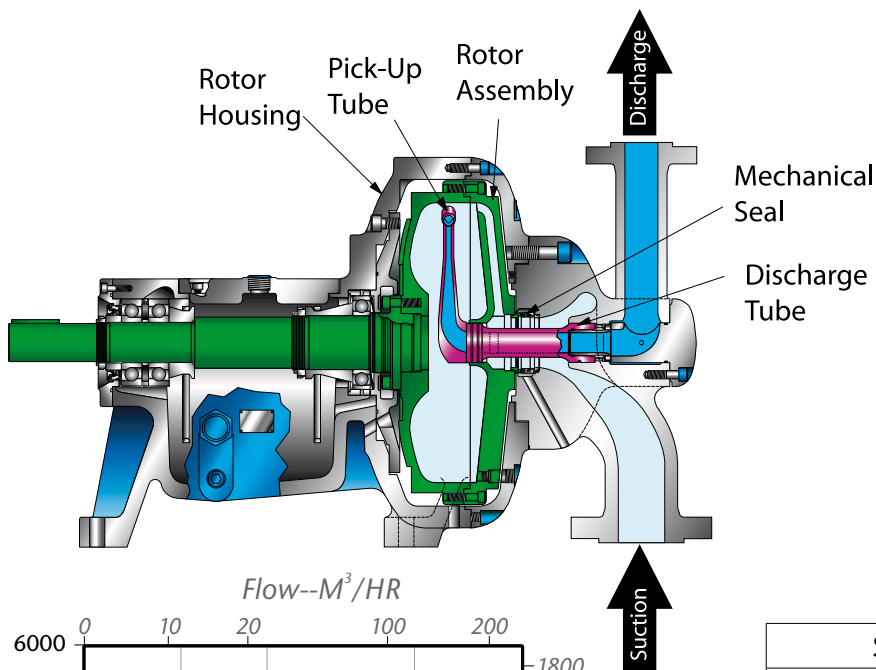

Typical Roto-Jet Model 2200 Applications

- Food and Beverage cleaning systems
- Reverse osmosis systems
- NOX Suppression
- Spraying/washing systems
- High pressure paper shower
- Circuit board wash systems
- Water/process injection systems
- Boiler feed/cleaning systems
- Desuperheating/condensate return
- And many, many more...

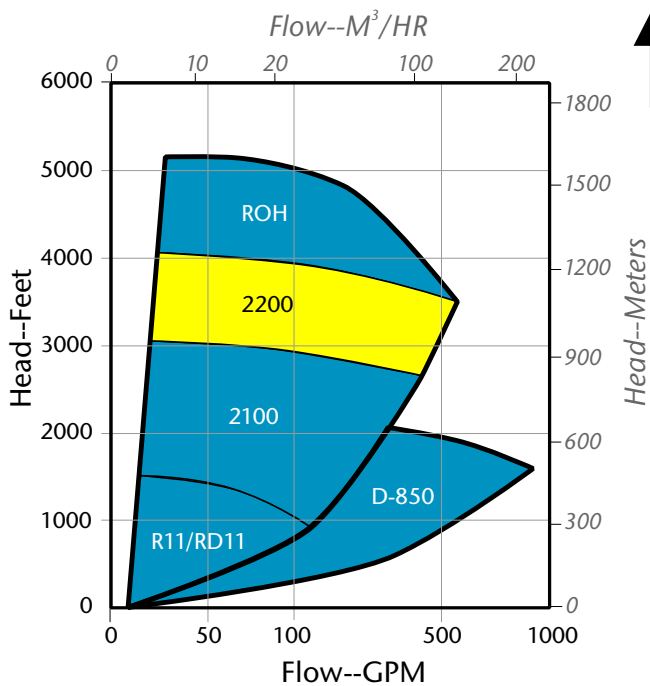

Specifications - Model 2200	
Maximum Temperature	180°F/82°C
Max Temperature - w/flush	250°F/121°C
Maximum Suction Pressure	200 PSI/14 Bar
Maximum Head	4042Ft./1232 m
Maximum Speed	5443 RPM
Maximum Flow	535GPM/121.5m ³ /hr
Maximum Horsepower	400 HP/290 KW
Weight	985 Lbs./447 Kg
Lubrication	Oil

Materials of Construction	Stainless Steel Pump	Ductile Iron Pump
Rotor	316. SS	Ductile Iron
Rotor Cover	316. SS	Ductile Iron
Manifold	316. SS	Ductile Iron
Endbell	Ductile Iron	Ductile Iron
Pickup Tube	17-4 PH	17-4 PH
Shaft	AISI-4140	AISI 4140

Note:
Dimensions are for general reference only and will vary with actual model selected. Available with flanged connections.

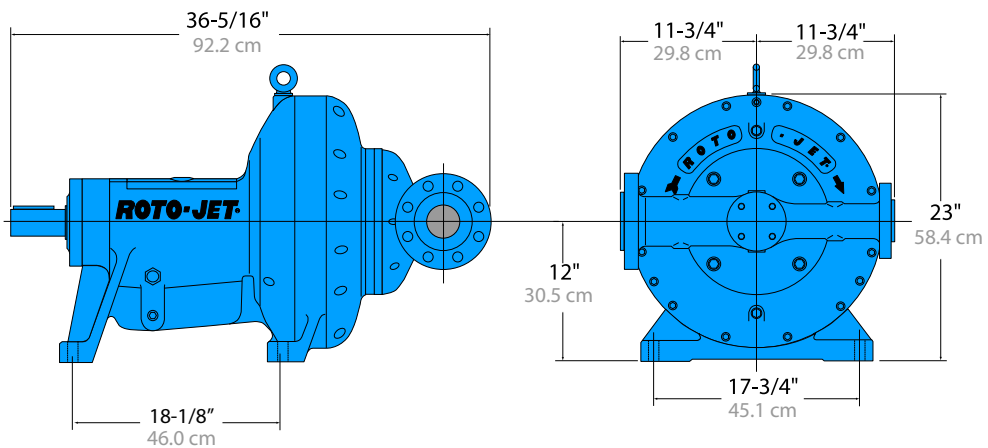

Weir Specialty Pumps

440 W. 800 South
P.O. Box 209 (84110-0209)
Salt Lake City, UT 84101
USA

Tel: 1 801 359 8731
Fax: 1 801 530 7531
email: info@weirsp.com
www.weirsp.com

© 2009 Weir Specialty Pumps. All Rights reserved. Bulletin RJ-2200

Excellent
Power & Industrial
Solutions

