

ROTO-JET PUMP

High Pressure Pitot Tube Pumps

Excellent
Power & Industrial
Solutions



Model R11®

High Pressure Single Stage Centrifugal Pump With Advanced Pitot Tube Technology

Advanced Design

- High pressure without high speed
- Flexible - performance can be adjusted by changing the pitot tube
- Simple - only two basic working parts

Dependable performance

- Hydraulically stable along the entire performance curve and beyond BEP
- Low minimum flow requirement
- Rugged design - most reliable high pressure pump in the marketplace

Enhanced Reliability

- Smooth, pulsation-free flow
- Low pressure mechanical seal is easily maintained
- Isolated bearing pedestal minimizes risk of bearing contamination

R11® Pump Features

- Materials of construction: ductile iron or 316 stainless steel
- Single or double mechanical seal
- Threaded connections
- Oil lubricated bearings



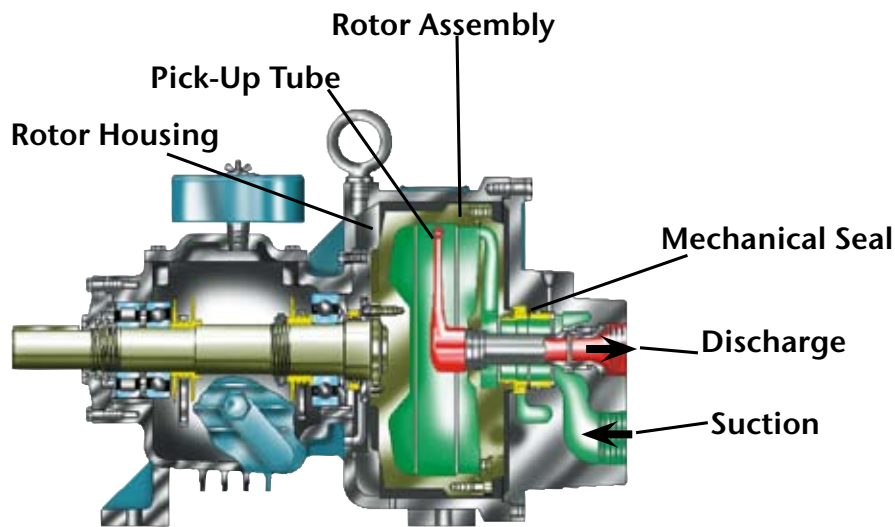

R-11 cut-away view

Typical Roto-Jet Model R11® Applications

- Food and Beverage cleaning systems
- Reverse osmosis systems
- Automotive gun drilling coolant
- Spraying/washing systems
- High pressure paper shower
- Circuit board wash systems
- Water/process injection systems
- Seal flushing systems
- Boiler feed/cleaning systems
- And many, many more...

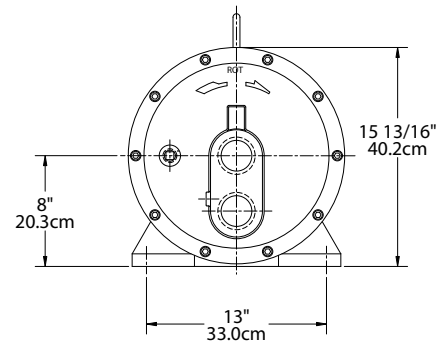
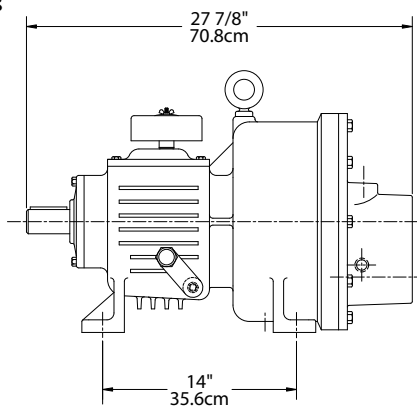

Note: Dimensions are for general reference only and will vary with actual model selected.

Operating Range

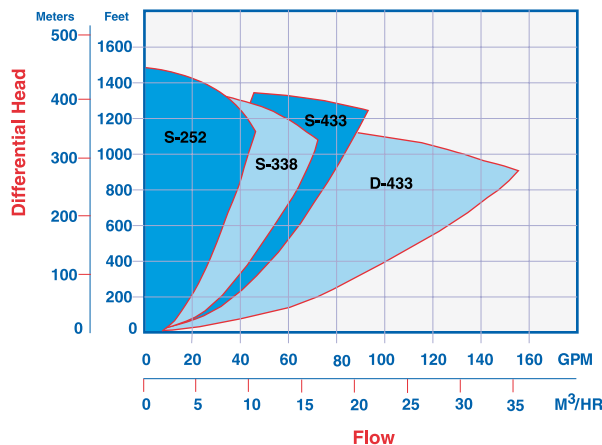

Specifications	R11®	
Maximum Temperature (with flush)	180° F	82° C
Maximum Suction Pressure	250° F	121° C
Maximum Head	200 PSI	14 BAR
Maximum Speed	1500 Ft.	457 m
Maximum Flow	4858 RPM	4858 RPM
Maximum Horsepower	150 GPM	34 m³/hr
Weight	75 HP	55 KW
	350 lbs.	159 kg
Materials of Construction		
	Standard	Stainless Steel
Rotor	Ductile Iron	316 St. Steel
Rotor Cover	Ductile Iron	316 St. Steel
Manifold	Ductile Iron	316 St. Steel
Endbell	Ductile Iron	316 St. Steel
Pick-up Tube*	17-4 PH	17-4 PH
Shaft	AISI 4140	AISI 4140

*Also available in 718 Inconel.

Weir Specialty Pumps

440 W. 800 South
P.O. Box 209 (84110-0209)
Salt Lake City, UT 84101
USA

Tel: 1 801 359 8731
Fax: 1 801 530 7531
email: info@weirsp.com
www.weirsp.com

© 2009 Weir Specialty Pumps. All Rights reserved. Bulletin RJ-R11

Excellent
Power & Industrial
Solutions

