

ROTO-JET PUMP

High Pressure Pitot Tube Pumps

Excellent
Power & Industrial
Solutions



Model RD11®

High pressure multi-stage performance with the cost advantage, simplicity and reliability of a single stage pump

Benefits of the Roto-Jet RD11 Pump

- **Lower Cost**
 - Lower Installed Cost—compact design eliminates installation issues
 - Efficient Operation—excellent energy saving efficiencies
 - Low Maintenance Cost—fewer components means less maintenance
- **Enhanced Reliability**
 - Fewer components to fail—no pump bearings, belts, couplings, or gears
 - Seal designed for low pressure—improves overall seal life
 - No coupling—eliminates coupling alignment and related failures
- **Improved Performance**
 - Broad range of speed, flow, and pressure capability
 - Hydraulically stable along the entire performance curve and beyond BEP
 - Adjustable to changing system flow conditions—flexible application

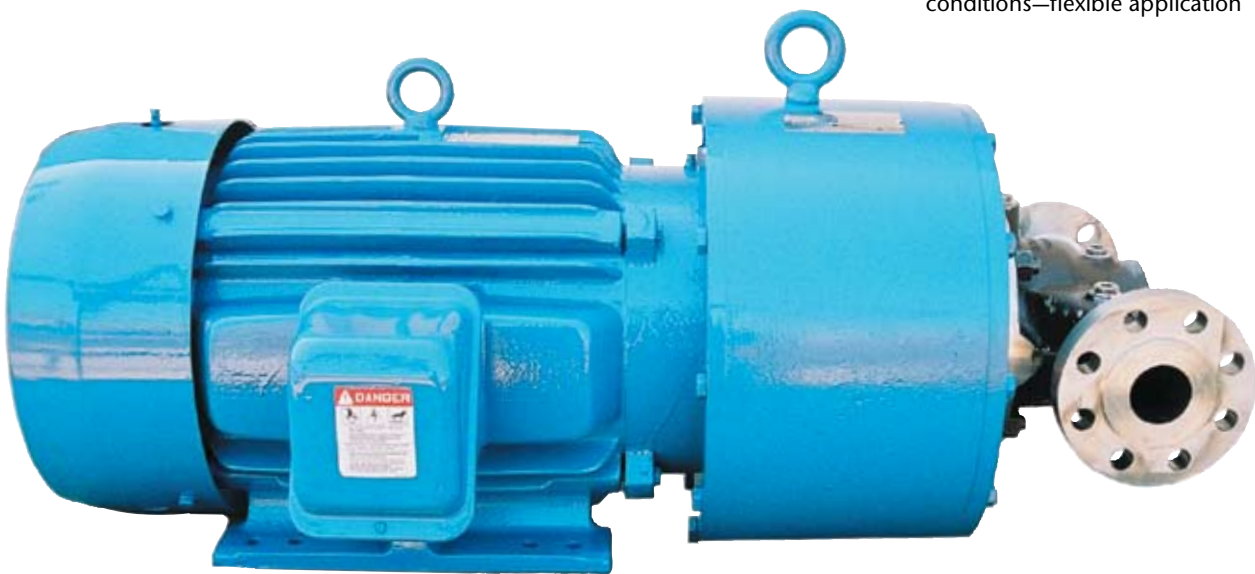

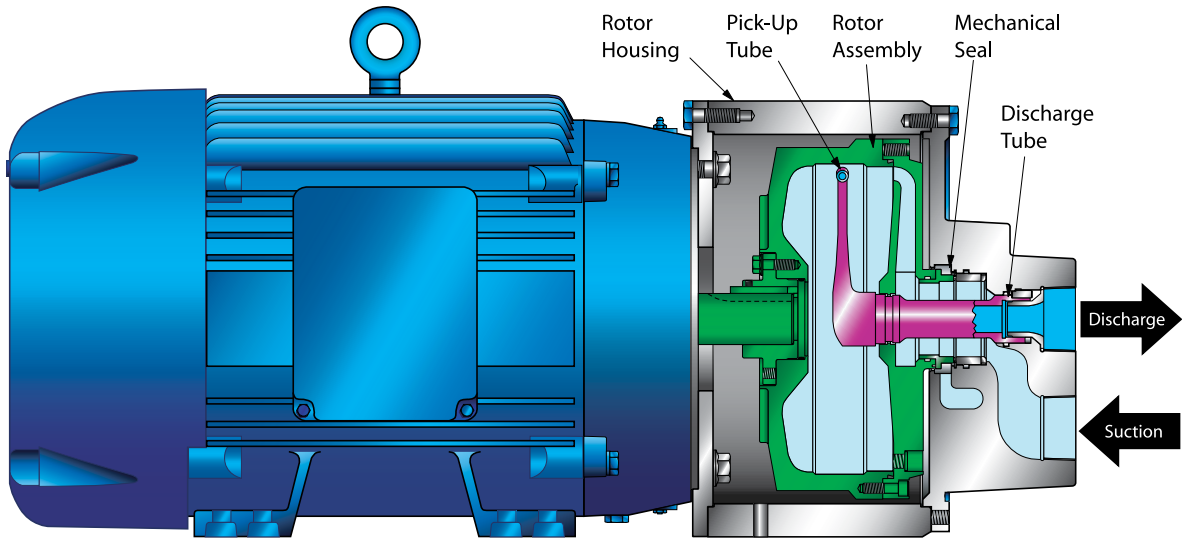

NOTE: Available With Flanged Connections

Typical Roto-Jet RD11 Applications

- Food & beverage cleaning systems
- Reverse osmosis systems
- Boiler feed/cleaning systems
- High pressure paper shower
- Circuit board wash systems
- Water/process injection systems
- Seal flushing systems
- Desuperheating/condensate return
- And many, many more...

Specifications	English	Metric
Maximum Temperature (With Flush)	180° F	82° C
Maximum Suction Pressure	250° F	121° C
Maximum Head	200 PSI	14 BAR
Maximum Speed*	1500 Ft.	457 m
Maximum Flow	4858 RPM	4858 RPM
Maximum Horsepower	150 GPM	34 m ³ /hr
Maximum Weight	75 HP	55 KW
	973 lbs.	441 kg
Materials of Construction		
	Standard	St. Steel
Rotor	Ductile Iron	316 St. Steel
Rotor Cover	Ductile Iron	316 St. Steel
Manifold	Ductile Iron	316 St. Steel
Endbell	Ductile Iron	316 St. Steel
Pickup Tube	17-4 PH	17-4 PH

*With VFD operation

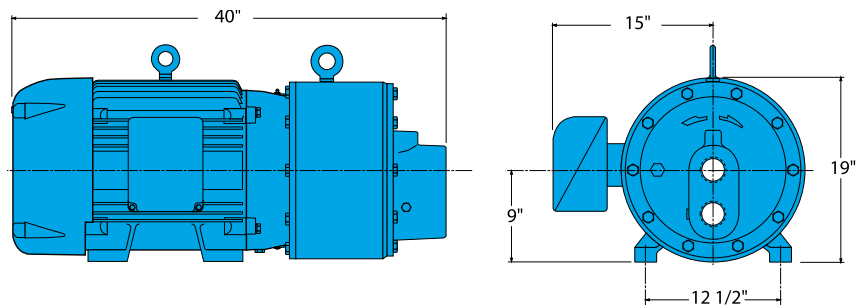
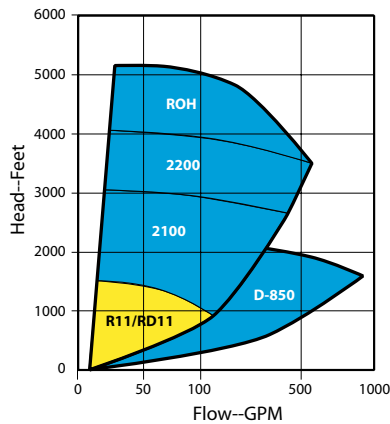

NOTE: Dimensions are for general reference only and will vary with actual model selected. Available with flanged connections.

Weir Specialty Pumps

440 W. 800 South
P.O. Box 209 (84110-0209)
Salt Lake City, UT 84101
USA

Tel: 1 801 359 8731
Fax: 1 801 530 7531
email: info@weirsp.com
www.weirsp.com

© 2009 Weir Specialty Pumps. All Rights reserved. Bulletin RD-R11

Excellent
Power & Industrial
Solutions

