

ROTO-JET PUMP

High Pressure Pitot Tube Pumps

Model RO®
Oil Lubricated

Excellent
Power & Industrial
Solutions



High Pressure Single Stage Centrifugal Pump With Advanced Pitot Tube Technology

Advanced Design

- High pressure without high speed
- Flexible - performance can be adjusted by changing the pitot tube
- Simple - only two basic working parts

Dependable performance

- Hydraulically stable along the entire performance curve and beyond BEP
- Low minimum flow requirement
- Rugged design - most reliable high pressure pump in the marketplace

Enhanced Reliability

- Smooth, pulsation-free flow
- Low pressure mechanical seal is easily maintained
- Isolated bearing pedestal to minimize risk of bearing contamination

RO® Pump Features

- API design available
- Single or double mechanical seal
- Threaded or flanged connections
- Materials of construction: ductile iron, carbon steel, 316 stainless steel, CA6NM, and CD4MCu. Super duplex and Hastelloy are also available
- Oil lubricated bearings

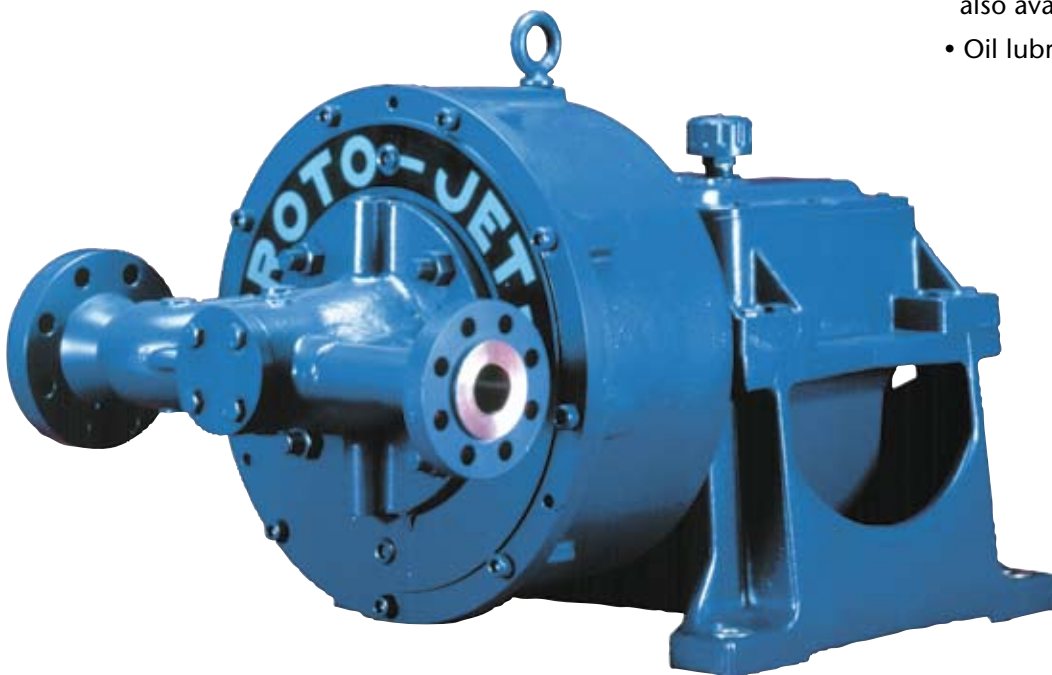

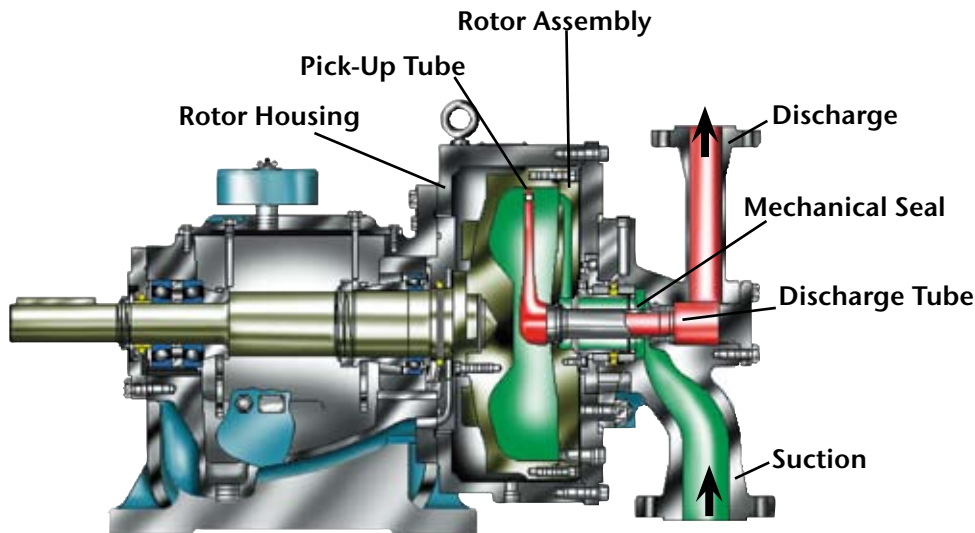

RO cut-away view

Typical Roto-Jet Model RO® Applications

- Food and Beverage cleaning systems
- Reverse osmosis systems
- Automotive gun drilling coolant
- Spraying/washing systems
- High pressure paper shower
- Circuit board wash systems
- Water/process injection systems
- Seal flushing systems
- Boiler feed/cleaning systems
- And many, many more...

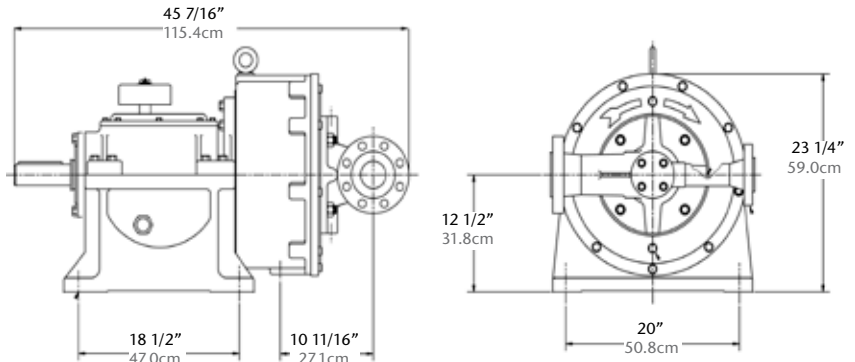

Note: Dimensions are for general reference only and will vary with actual model selected.

Operating Range

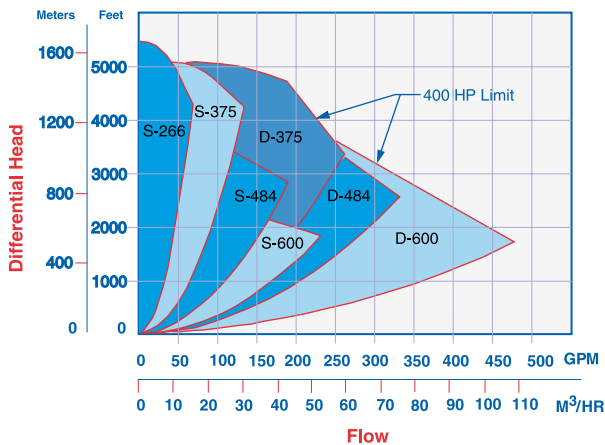

Specifications

	RO®		High Speed Opt.	
Maximum Temperature	250° F	121° C	250° F	121° C
(With flush)	550° F	288° C	550° F	288° C
Maximum Suction Pressure	400 PSI	28 BAR	300 PSI	21 BAR
Maximum Head	2600 Ft.	792 m	5200 Ft.	1585 m
Maximum Speed	4380 RPM	4380 RPM	6321 RPM	6321 RPM
Maximum Flow	450 GPM	102 m³/hr	600GPM	136 m³/hr
Maximum Horsepower	400 HP	300 KW	600 HP	447 KW
Weight	1200 lbs.	544 kg	1200 lbs.	544 kg

Materials of Construction

Rotor*	Steel	St. Steel	Steel/ CA 6NM	St. Steel/ CD4MCu
Rotor Cover*	Carbon Steel	316 St. Steel	CA 6NM	CD4MCu
Manifold*	Carbon Steel	316 St. Steel	CA 6NM	CD4MCu
Endbell	Carbon Steel	316 St. Steel	Carbon Steel	316 St. Steel
Pick-up Tube**	Carbon Steel	Carbon Steel	Carbon Steel	Carbon Steel
Shaft	17-4 PH	17-4 PH	17-4 PH	17-4 PH
	AISI 4140	AISI 4140	AISI 4140	AISI 4140

* RO Model also available in Ductile Iron & Hastelloy C **also available in 718 Inconel

Weir Specialty Pumps

440 W. 800 South
P.O. Box 209 (84110-0209)
Salt Lake City, UT 84101
USA

Tel: 1 801 359 8731
Fax: 1 801 530 7531
email: info@weirsp.com
www.weirsp.com

© 2009 Weir Specialty Pumps. All Rights reserved. Bulletin RJ-RO

Excellent
Power & Industrial
Solutions

