

Weir Oil and Gas | Australia

Providing products, services and engineering excellence for Australia's offshore, marine and onshore oil and gas industry.

Excellent
Oil & Gas
Solutions



First choice for oil and gas in Australia



Meeting the needs of the oil and gas sector in Australia



Key customers

- Bechtel
- BJ Services
- BP Exploration
- Caltex
- Chevron
- Clough Engineering
- Conoco Phillips
- Esso
- Foster Wheeler
- General Electric
- Halliburton
- KPR
- Marathon
- Petrofac
- Schlumberger
- Shell
- Weatherford
- Woodside Energy

Weir Oil & Gas is committed to delivering market leading products and services which meet the technical and commercial challenges of customers operating across the full spectrum of onshore, offshore, and marine oil and gas activities throughout Australia.

All of Weir's divisions support the oil sector in many ways – upstream and downstream, ready to assist exploration and operations from the finds in the Carnarvon Basin, offshore in the Sydney Basin, natural gas deposits in Tasmania and subsea in the Vulcan sub basin and some of the deepest oceans meeting the needs of leading oil names such as Esso and Conoco Phillips.

Weir Group divisions offer solutions which are used throughout each step of the process – from **Drilling and Well Completion, Production, Pipeline and Transportation, to Refining and Petrochemical operations.** And the Weir Group provides the **Service and Support** to assist the Oil and Gas industry each step of the way – from consultative support and installation through training, maintenance and re-rates.

Weir Oil & Gas and the other Weir Group divisions' brand portfolio in the Oil and Gas Sector

Weir Oil & Gas

GABBIONETA™
API 610 Pumps

SPM®
Well Service Pumps
& Flow Control Products

**WEIR PETROLEUM
CERTIFICATION
SERVICES™**
Inspection
& Re-certification Services

**WEIR OIL & GAS
SERVICES™**

Weir Minerals

FLOWAY® PUMPS
Vertical Turbine Pumps

HAZLETON®
Specialty Slurry Pumps

BEGEMANN PUMPS™
Centrifugal Process Pumps

WEIR LGE

Weir Power & Industrial

**ALLEN STEAM
TURBINES**
Single & Multi-stage Steam
Turbines

**ATWOOD &
MORRILL®**
Engineered Isolation & Check
Valves

BATLEY VALVES®
High Performance Butterfly Valves

BLAKEBOROUGH®
Controls & Severe Service Valves

HOPKINSONS®
Parallel Slide Gate & Globe Valves

MAC VALVES®
Ball & Rotary Gate Valves

SARASIN-RSBD™
Pressure Safety Devices

TRICENTRIC®
Triple Offset Butterfly Valves

Drilling and Well Completion

- Pumps, valves and related flow control equipment for well service and stimulation applications
- Iron rental, recertification and sale of replacement units

Production

- Pumps and valves for onshore and offshore production applications
- Rotary equipment, asset management, repair and upgrade services

Pipeline and Transportation

- Oil and products pipeline pumps, valves and associated repair and upgrade services
- Process engineering solutions relating to petrochemical and liquid gas transportation and handling

Refining and Petrochemicals

- Pumps, valves and steam turbines for oil refinery and petrochemical applications

Service and Support

Repair and spares > Iron recertification and rentals > Asset management > Upgrades and re-rates > Engineering support > Re-Engineering > Reactive maintenance > Training

Drilling and Well completion

Product brands

- WEIR PETROLEUM CERTIFICATION SERVICES™**
Inspection & Re-certification Services
- SPM®**
Well Service Pumps & Flow Control Products
- BLAKEBOROUGH®**
Controls & Severe Service Valves
- MAG VALVES**
Ball & Rotary Gate Valves
- WEIR OIL & GAS SERVICES™**



Weir Oil & Gas meets the needs of the drilling and well completion market through a family of brands that each have decades of experience servicing the needs of this constantly evolving market.

Weir Oil & Gas Division thoroughly covers the well service and completion segment through a broad range of product lines and post-sale services. The SPM® range of well service pumps and flow control products is a worldwide leader in well service and stimulation pumps, high-pressure flow control products. The Division also provides safety products, and post-sale recertification and repair services through its expansive network of service facilities, which is also supported by the Weir Services business unit.



1. Weir Oil & Gas offers SPM® pump high-pressure flow control rental units, which enable rapid response shipment of critical equipment for offshore operations
2. Weir's professionally trained technicians perform recertification services on high-pressure, well service flow control equipment



Production



Product brands

FLOWAY® PUMPS
Vertical Turbine Pumps

BEGEMANN PUMPS™
Centrifugal Process Pumps

ALLEN STEAM TURBINES
Single & Multi-stage Steam Turbines

BATLEY VALVES®
High Performance Butterfly Valves

BLAKEBOROUGH®
Controls & Severe Service Valves

MAC VALVES®
Ball & Rotary Gate Valves

SARASIN-RSBD™
Pressure Safety Devices

TRICENTRIC®
Triple Offset Butterfly Valves

WEIR OIL & GAS SERVICES™

During the production phase, it is of upmost importance to utilise the most effective resources to ensure equipment operates effectively and reliably.

Weir meets these demands through its offering of many of the industry's most reliable products and services. Engineering and field services, project management, pump, turbine and compressor repair, as well as engineered component parts for pumps and other equipment are offered through the Weir Oil and Gas Services network throughout Australia.

The Weir Group manufactures a full range of valves for onshore, offshore and subsea applications. The main product range includes Control, Choke, Safety, Isolation and Chemical Injection Valves. These valves are produced in a wide variety of sizes and materials and are already well proven to meet the arduous operating environments where engineered valve solutions are required, including severe service applications. These include "Deep" & "Ultra Deep" operating conditions on Choke & Chemical Injection applications.

Contract handling through every stage is geared to meet the fast response times required in the Oil and Gas industry, with proven success in supplying special design valves on short lead times.



1.

1. Bidirectional Blakeborough® choke valves for oil and gas production with a specially designed trim to prevent blockage due to large amounts of sand in the production flow. The valve can also be reversed for water injection.
2. Floway® Pumps are used in a variety of oil and gas applications both upstream and downstream including pipeline, offshore platforms and refineries
3. The MAC Valve® chemical injection rotary gate valve offers a unique solution to the dosing of MEG in low temperature applications. The valve is cavity-free and will not block up as a result of fluid contamination, thus eliminating the formation of hydrates in subsea applications



2.



3.

Pipeline and Transportation

Product brands

GABBIONETA™
API 610 Pumps

BEGEMANN PUMPS™
Centrifugal Process Pumps

BATLEY VALVES®
High Performance Butterfly Valves

BLAKEBOROUGH®
Controls & Severe Service Valves

SARASIN-RSBD™
Pressure Safety Devices

TRICENTRIC®
Triple Offset Butterfly Valves

WEIR LGE

WEIR OIL & GAS SERVICES™



The Weir Group supports the pipeline and transportation markets through a vast array of product and service offerings.

Weir LGE Process designs and builds plants for the processing, storage and handling of liquid gases and is a market leader in supplying these solutions to the marine and onshore sectors. From sophisticated liquid gas carriers for world wide trade, to large +100,000 m3 import/export terminals, LGE adopts a customer focused approach and provides the client with the solution best suited to their needs.

Gabbioneta™ API centrifugal pumps are designed and manufactured by Weir Gabbioneta, and operate in a wide variety of operations including single stage overhung, to horizontal and vertical multistage pumps. From heavy duty process applications to complex packaged equipment, Weir Gabbioneta offers a leading brand product with more than 30 years of experience supporting both the transportation and refinery markets.

From crude oil to refined products, Weir Services has proven services, both field and shop, to meet the operation and maintenance needs of the pipeline and transportation industry.

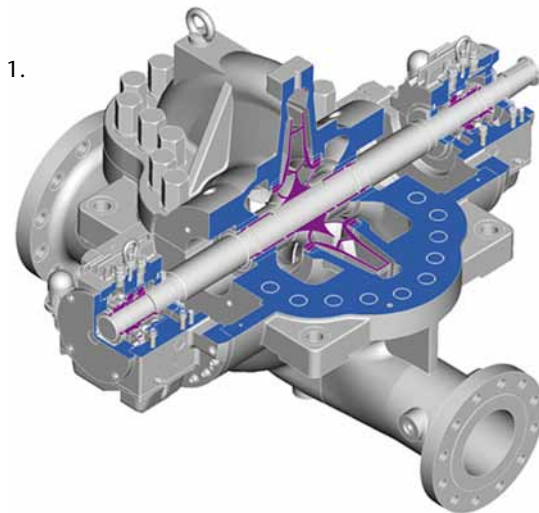

1. *Gabbioneta™ AXD heavy duty pumps are horizontal, between bearings with a axially split casing, and double suction impeller fully designed according to latest edition of API 610 std.*

2. *Gabbioneta™ AXD pumps prepared for installation*



Refining and Petrochemicals



The increasing global demand for refined petroleum products and petrochemicals forces refineries to seek constant upgrades to equipment and engineered services to maximise the efficiencies of their facilities.

The Weir Group meets these needs through a breadth of products and services designed to upgrade customers' facilities and increase production.

From the Gabbioneta™ API 610 process pump, to Floway® Pumps, Hazleton® pumps, and Begemann™ process pumps, Weir's portfolio of pumps leads the industry with custom solutions for severe service applications. Along with reliable services including pump, turbine and compressor repair, engineering support and OEM replacement parts provided by Weir Services are available to provide turnkey support in the world's foremost refining markets.

Weir supports the refinery and petrochemical industries with an analysis and configuration system designed to create optimum valve and control solutions for Control, Safety and Isolation valves across a range of sizes and materials to protect the value of refining and petrochemical processes.



1.

Product brands

GABBIONETA™
API 610 Pumps

FLOWAY® PUMPS
Vertical Turbine Pumps

HAZLETON®
Specialty Slurry Pumps

BEGEMANN PUMPS™
Centrifugal Process Pumps

ALLEN STEAM TURBINES
Single & Multi-stage Steam Turbines

ATWOOD & MORRILL®
Engineered Isolation & Check Valves

BATLEY VALVES®
High Performance Butterfly Valves

BLAKEBOROUGH®
Controls & Severe Service Valves

HOPKINSONS®
Parallel Slide Gate & Globe Valves

SARASIN-RSBD™
Pressure Safety Devices

TRICENTRIC®
Triple Offset Butterfly Valves

WEIR OIL & GAS SERVICES™

1. The Hazleton® VSM is a heavy duty coke fine vertical pump is a triple volute, high pressure sparge pump system
2. The Gabbioneta™ R line heavy duty process pumps are horizontal, radially split, centerline supported, single entry overhung impeller, designed in a back pull-out configuration according to latest edition of API 610 Std
3. The range of Sarasin-RSBD™ pilot-operated safety relief valves perform in temperatures from -196 degrees C to +550 degrees C and has minimal maintenance requirements



2.



3.

Service and Support

Product brands serviced

GABBIONETA™
API 610 Pumps

SPM®
Well Service Pumps
& Flow Control Products

**WEIR PETROLEUM
CERTIFICATION
SERVICES™**
Inspection
& Re-certification Services

FLOWAY® PUMPS
Vertical Turbine Pumps

HAZLETON®
Specialty Slurry Pumps

BEGEMANN PUMPS™
Centrifugal Process Pumps

**ALLEN STEAM
TURBINES**
Single & Multi-stage Steam
Turbines

**ATWOOD &
MORRILL®**
Engineered Isolation & Check
Valves

BATLEY VALVES®
High Performance Butterfly Valves

BLAKEBOROUGH®
Controls & Severe Service Valves

HOPKINSONS®
Parallel Slide Gate & Globe Valves

MAC VALVES®
Ball & Rotary Gate Valves

SARASIN-RSBD™
Pressure Safety Devices

TRICENTRIC®
Triple Offset Butterfly Valves

WEIR LGE

...also servicing myriad
competitive brands

1. *Installing a Floway® vertical turbine pump*
2. *Complete overhaul of main control valve at refinery by Weir Oil & Gas Services*
3. *Our complete range of compressor services includes re-rating and upgrading the compressor train for onshore and offshore installations*



Through its highly skilled service facilities, Weir Oil & Gas Services also sets the pace in the repair and refurbishing of large or critical rotating and stationary equipment, both in-shop and on-site. Engineering teams look after products including pumps, fans and blowers, compressors and heat exchangers and work with customers on upgrades including specific coatings to increase or improve performance.

Further, with an intensive long term history in pump design and manufacture, we have the in-house expertise in hydraulic design to implement changes to equipment to improve efficiencies and to reduce the wear rate that causes downtime - including update and redesign of pumps to the latest engineering practices.

Importantly, with our engineering expertise, leading edge service facilities around the nation and support of the Weir global network, customers can be assured of the best service solution every time.



Weir Oil & Gas – Australia

20 Stuart Dr
Henderson WA 6166
Australia

T +61 (0)8 9410 7500
F +61 (0)8 9410 7500
spm@weir.com.au

Excellent
Oil & Gas
Solutions



SPM®

Well Service Pumps & Flow
Control Products

Perth

20 Stuart Dr
Henderson WA 6166
Australia
T +61 8 9410 7500
F +61 8 9410 7500

WEIR PETROLEUM CERTIFICATION SERVICES™

Inspection & Re-certification
Services

Adelaide

83 Rundle Road,
Salisbury South SA 5106
P +61 8 8285 3133
F +61 8 8285 3151

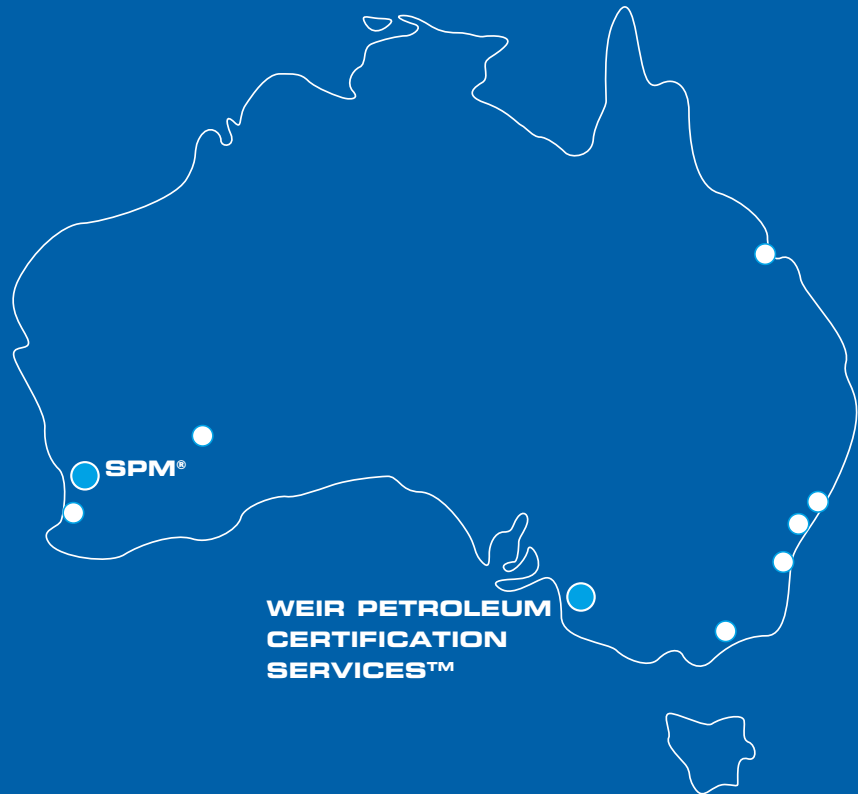

Field Services	HQ	Somersby	15 Gindurra Road Somersby NSW 2250	Tel: +61 2 4349 2999 Fax: +61 2 4349 2900
Service Centres	NSW	Beresfield	9 Arunga Drive Beresfield NSW 2322	Tel: +61 2 4032 9400 Fax: +61 2 4032 9497
		Wollongong	10 Tate Street Wollongong NSW 2500	Tel: +61 2 4227 4022 Fax: +61 2 4227 4088
	QLD	Rockhampton	80 McLaughlin Street N Rockhampton QLD 4701	Tel: +61 7 4924 7700 Fax: +61 7 4924 7799
	VIC	Sale	24 Hunt Place Wurruk VIC 3850	Tel: +61 3 5144 5933 Fax: +61 3 5144 1708
	WA	Kalgoorlie	30 Atbara Street Kalgoorlie WA 6430	Tel: +61 8 9021 1454 Fax: +61 8 9021 1468
		Bunbury	1 Shanahan Road Bunbury WA 6230	Tel: +61 8 9726 2301 Fax: +61 8 9726 2303