

WEIR SPLIT CASE

Single-Stage Double-Suction Pumps

**Designed to simplify maintenance and
reduce life-cycle costs**

Excellent
Power & Industrial
Solutions



Weir Split Case Pumps™

- The Weir Split Case pump is designed to make maintenance straight forward, minimizing operating costs and increasing the pump's overall life span.

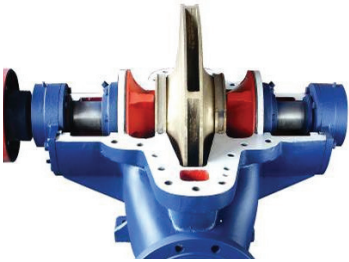

Photos: Above, Weir Split Case shown with top cover removed. To the right, Weir Split Case pumps installation.

High efficiency, low vibration, & easy maintenance

Weir Split Case single-stage double suction centrifugal pumps are designed and developed using advanced technology to meet demanding market requirements. The Weir Split Case combines high efficiency, low vibration, and easy maintenance that provides the customer with a pump that has a extended operational life.

The Weir Split Case is designed with the latest 3D computer aided design technology. We utilize the proven lean manufacturing processes with dedicated production units that equals less waste and greater efficiency. All of this combined allows us to provide the highest quality pumps and components, delivered on-time at a competitive price.

Capabilities

- Flow*: up to 132,000 GPM / 30,000 m³/hr
- Head*: up to 755 ft. / 230 m
- Diameter inlet / outlet: 150 mm to 1600 mm
- Horizontally coupled design
- Vertically coupled design

Benefits

- High Efficiency
- Low Vibration
- Easy Maintenance
- Extended Operational Life
- Lower Cost
- Improved Performance

Applications

- Water Supply
- Wastewater
- Pulp & Paper
- Petrochemical
- Power Industry
- General Industry



WEIR Split Case Material Specification

Parts Name	Material Specification 1	Material Specification 2	Material Specification 3
Pump Casing	Cast Iron (GG25)	Ductile Iron (GGG40)	
Pump Cover	Cast Iron (GG25)	Ductile Iron (GGG40)	
Impeller	Cast Iron (GG20)	Bronze (G-CuSn10Zn)	Bronze (G-CuZn15Si4)
Seal Ring	Cast Iron (GG20)	Bronze (G-CuSn10Zn)	Bronze (G-CuZn15Si4)
Seal Body	Cast Iron (GG20)	Ductile Iron (GGG40)	
Shaft	Carbon Steel (CK45)	Alloyed Steel (41Cr4)	Stainless Steel (420)
Shaft Sleeve	Cast Iron (GG20)	Stainless Steel (420)	

* For expanded flows and heads, see large capacity brochure.

The Weir Split Case™ series single stage double suction centrifugal pumps are designed and developed using advanced technology to meet demanding market requirements.



IMPELLER

Dynamically balanced double-suction impeller is designed using the latest in 3D computer technology to optimize hydraulic performance and minimize axial forces. Each impeller can be tailored to the customer's design conditions.

CASING

The double-volute casing is designed to reduce radial forces resulting in lower bearing loads and longer service life. Upper case is easily disassembled and adjustments made without disturbing suction and discharge piping. Pump inlet and outlet connections can be reversed to meet customers site requirements.

BEARINGS

Standard construction includes oversized grease lubricated ball bearings. Oil lubricated bearings are also available as required.

SEALING OPTIONS

Stuffing box is available with either non-asbestos soft packing or a wide range of mechanical seal arrangements. The shaft is protected by a stainless steel shaft sleeve.

SHAFT

Alloy shaft is equipped with a renewable sleeve to protect the shaft from the pump liquid. Shaft is available in various materials ranging from (CK45) carbon steel to (420) stainless steel.

BASEPLATE

Minimum 3/8" thick fabricated steel construction suitably reinforced to support the full weight of the pump and motor.

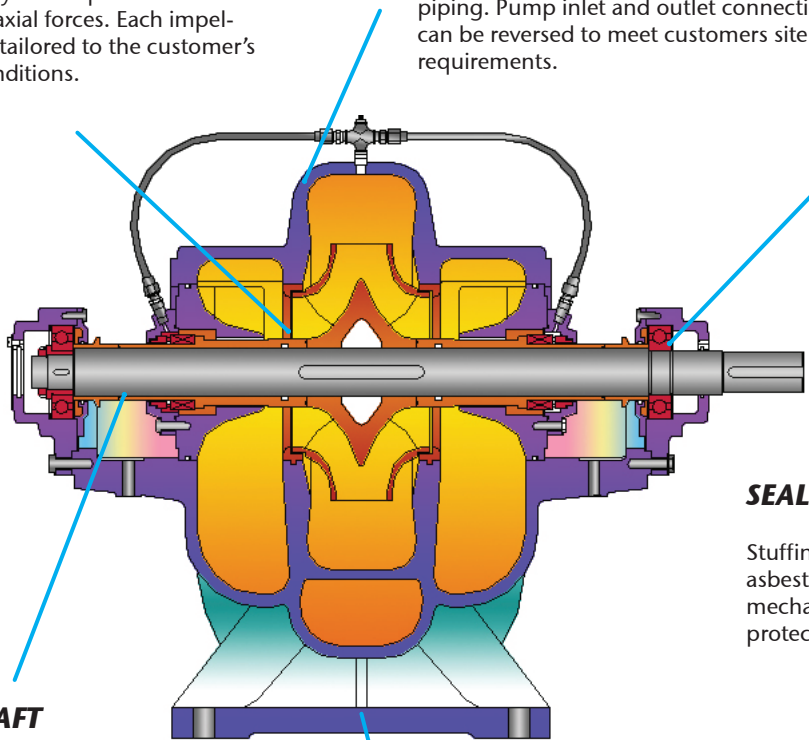

Photos: Above, installation of Weir Split Case pumps.

WEIR Split Case Performance Chart*

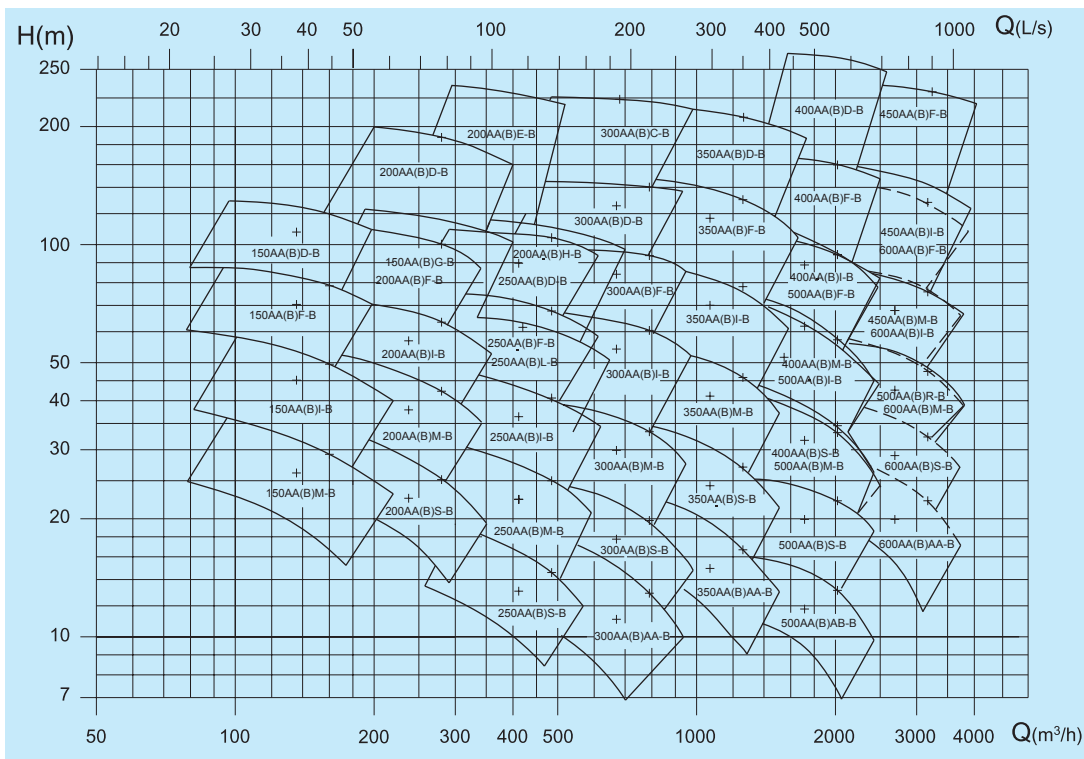

* For expanded flows and heads, see large capacity brochure.

Standard Type Installation

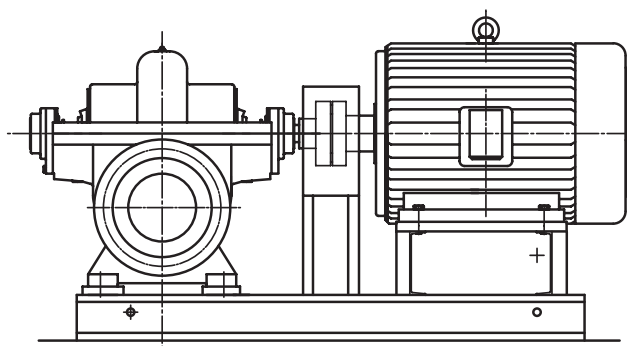
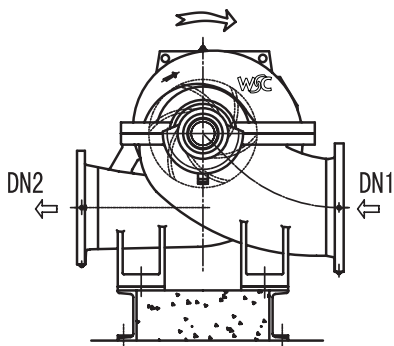

Weir Specialty Pumps

440 West 800 South
P.O. Box 209 (84110-0209)
Salt Lake City, UT 84101
USA

Tel: 801 359 8731
Fax: 801 530 7828
email: info@weirsp.com
www.weirsp.com

© 2009 Weir Specialty Pumps. All Rights Reserved. Brochure: Weir_Split_Case_Brochure

Excellent
Power & Industrial
Solutions

